

Hydraulic Component Assembly

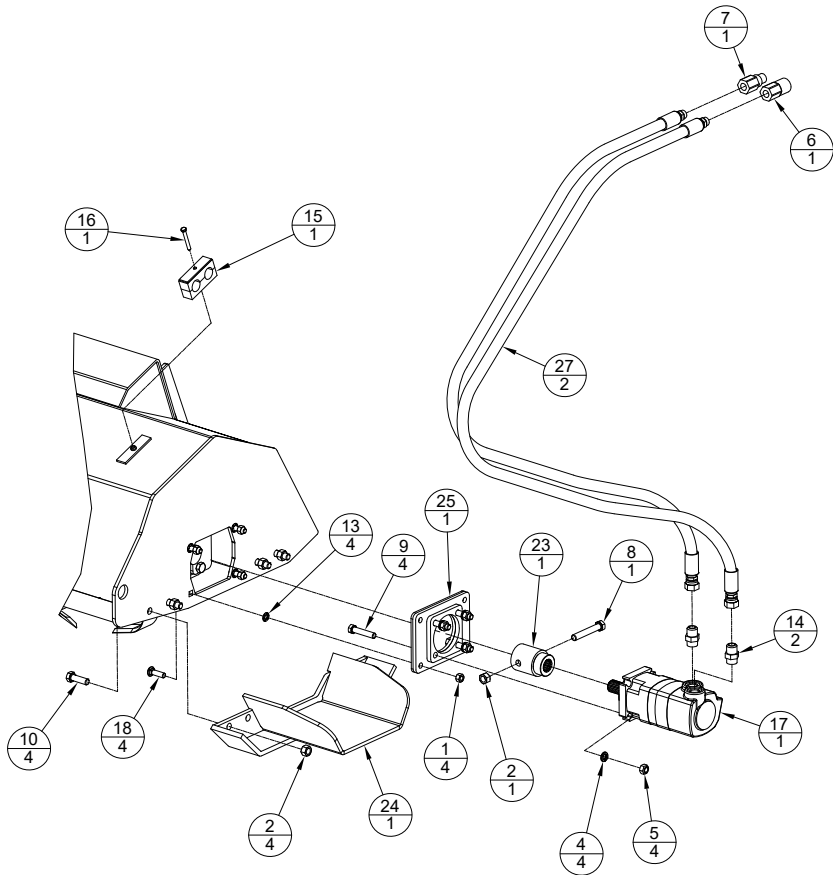

Tiller

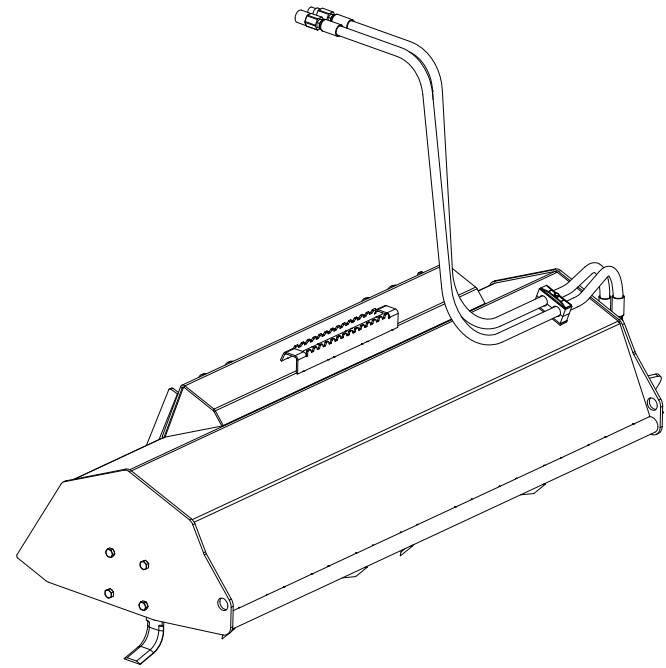

Model Number TLR.

Serial Number _____.

Serial Numbers 126126 - Current
Manufacture Date 08/15/17 - Current

Phone: 320-818-4040

01/01/14
Revised 08/15/17

Features of Virnig Mfg. Inc. Tiller include:

- 6" maximum tilling depth.
- Tiller rotor supported by two large 2" diameter bearings to minimize shock loads on motor shaft.
- Offset mounting allows the right side tracks of machine to be covered when doing finish tilling.
- 15-25 gpm operating flow rate range and 2000 – 3500 psi operating pressure range.
- Direct drive design with replaceable drive components.
- Aggressive heat treated dual edge replaceable tines.
- Recommended for loaders with an operating capacity greater than 1300 lb.

Initial Use

- For your records and to aid in ordering parts, if needed, please record the serial number of the attachment in the space provided on the inside front cover of this manual and store manual in safe place.
- Read and understand all warning information in this manual before operating this attachment.
- Check that quick-tach on frame fits onto loader properly. Pins must engage through 3/8" plates at bottom of quick-tach.
- Slowly roll back attachment. Make sure there is no interference between attachment and loader.
- Do not connect this attachment to high flow couplers.
- Make sure hoses do not pinch during roll back.
- Never exceed the maximum attachment operating pressure of 3500 psi.
- Since the tiller can rotate in either direction, the operator must determine which direction the tiller is rotating and match travel direction accordingly. It is recommended that tiller rotation is in the same direction as travel. For finish tilling, rearward travel is recommended with the tiller tines rotating rearward to give the best finish.

Tiller Main Component Assembly

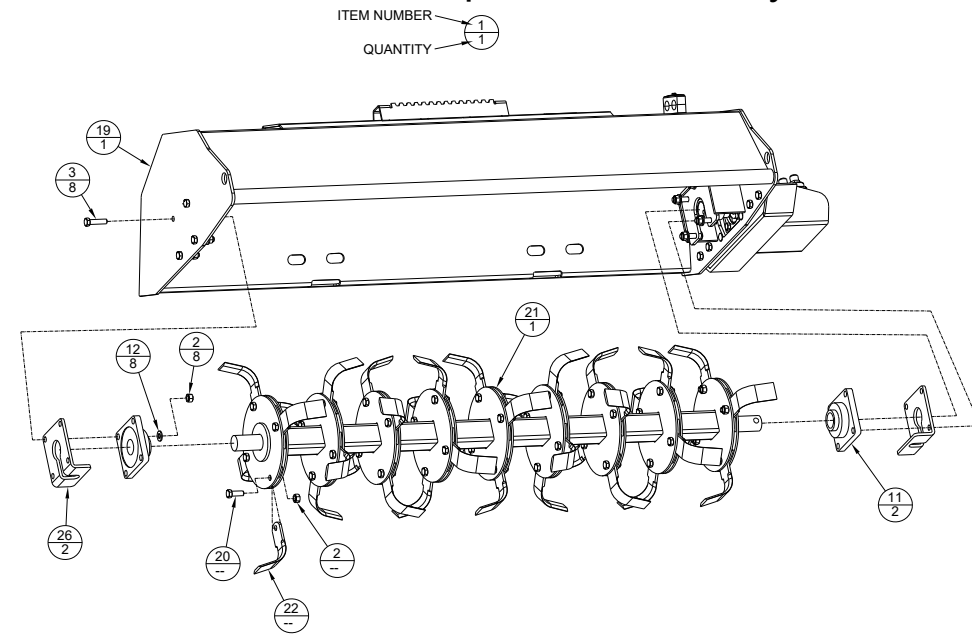

Tiller (TLR) Parts List (cont.)

Table 1

MODEL	TLR54	TLR72
5/8"-11 TOP LOCK NUT	41	49
TILLER FRAME WELDMENT	9292VW	9255VW
5/8"-11 X 1 3/4" LG HHCS GR8	28	36
TILLER ROTOR WELDMENT	9296VW	9263VW
TILLER TINE	28	36
HYD HOSE 3/4" 12MB TO 12FJX	8276PP-78" LG	11020PP-120" LG
WEIGHT (lb)	900	1025

Tiller Rotor Speed

FLOW RATE (gpm)	SPEED (rpm)
16	154
18	173
20	193
22	212
24	231

Speeds are the same for all widths.

Bolt Torque Chart

SIZE	GRADE 5		GRADE 8		SHCS*	
	COARSE	FINE	COARSE	FINE	COARSE	FINE
1/4"	6	7	9	10	10	12
5/16"	13	15	18	20	22	24
3/8"	23	26	33	37	38	43
7/16"	37	41	52	58	61	68
1/2"	57	64	80	90	93	105
9/16"	82	91	115	128	134	150
5/8"	113	128	159	180	179	202
3/4"	200	223	282	315	317	354

*SHCS—Socket Head Cap Screw

Values are in ft.-lb. and are recommended unless otherwise noted.

Operation

- Always follow safety and operating information in this manual.
- Always follow all safety and operating instructions of the loader.
- Never remove material deflectors or warning labels.
- Never operate tiller unless you have been properly trained.
- Make sure all safety labels are in place, look in this manual for their locations.
- Always relieve pressure before connecting or disconnecting hydraulic hoses.
- Clean any debris from attachment. Pay special attention to any debris in quick-tach area.
- Before tilling an area, thoroughly check for obstructions such as pipes, fence posts, wire/cable, rocks, etc. Remove obstructions if possible, flag any obstructions too large to move.
- If tine rotation does not match your preferred detent position, the couplers on the hoses can be switched.
- Stop and inspect entire unit for damage after striking any foreign objects. Replace or repair any damaged components before continuing.
- Engage hydraulics with the engine idling and tiller above the ground. Bring the engine speed to the desired rpm and lower machine boom to engage tiller into ground. Roll the tiller forward to desired position for tilling.
- Before disengaging hydraulics, remove tiller from the ground and idle engine down to minimize potential hydraulic motor damage.
- Allow tiller to stop completely before changing rotation direction of the tiller rotor as damage to the hydraulic motor may occur.

Tilling Recommendations

- It is recommended that tiller rotation is in the same direction as travel. For finish tilling, rearward travel is recommended with the tiller tines rotating rearward to give the best finish.

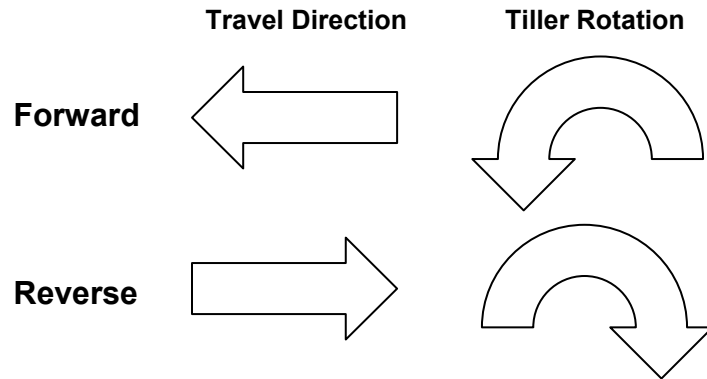

- If the tiller stalls, the travel speed is too fast or the tilling depth is too deep. Slow down travel speed or decrease tilling depth by raising the boom.
- Tilling under wet conditions is not recommended as the soil will stick to the tines and rotor and result in decreased tilling performance.
- When tilling sod or compacted soils, multiple passes may be required to achieve desired results.
- Mowing and removing tall grass and weeds before tilling an area will improve tiller performance since this will minimize wrapping of the grass and weeds around the tiller rotor.

Tiller (TLR) Parts List

ITEM	PART NO.	QTY	DESCRIPTION
	1	4	1/2"-13 REVERSE LOCK NUT
A	2	--	5/8"-11 TOP LOCK NUT
	3	8	5/8"-11 X2 1/2" LG HHCS
	4	4	9/16" HI-ALLOY LOCK WASHER
	5	4	9/16"-12 TOP LOCK NUT
	6	1	COUPLER FEMALE 12FB
	7	1	COUPLER MALE 12FB
	8	1	5/8"-11 X4" LG HHCS
	9	4	9/16"-12 X2 3/4" LG HHCS GR8
	10	4	5/8"-11 X2" LG HHCS
	11	2	2" BEARING W/4 HOLE FLANGE
	12	8	5/8" SAE FLAT WASHER
	13	4	1/2" PUSHNUT BOLT RETAINER
	14	2	ADAPTER 12MJ TO 12MB
B	15	1	CLAMP HOSE ASSEMBLY 3/4" HOSE
B	16	1	5/16"-18 X2 1/2" LG HHCS
	17	1	MOTOR PWR/TLR 24.0 CID 4K
	18	4	1/2"-13 X1 3/4" LG CB
A	19	1	TILLER FRAME WELDMENT
A	20	--	5/8"-11 X1 3/4" LG HHCS GR8
A	21	1	TILLER ROTOR WELDMENT
A	22	--	TILLER TINE
	23	1	TILLER DRIVE ADAPTER WELDMENT
	24	1	TILLER SKID SHOE WELDMENT
	25	1	TILLER MOTOR MOUNT WELDMENT
	26	2	TILLER BEARING GUARD
A	27	2	HYD HOSE 3/4" 12MB TO 12FJX

A – See Table 1.

B – Used only on TLR72.

Labels on Tiller Attachment (cont.)

25 GPM MAX

7490PP-25 GPM MAX LABEL

This label indicates the maximum flow rate for this attachment.

Tiller (TLR) Label Parts List

ITEM	PART NO.	QTY	DESCRIPTION
1	7490PP	1	25 GPM MAX LABEL
2	9391PP	1	54 WIDTH LABEL
	9397PP		72 WIDTH LABEL
3	9540PP	3	TILLER WARNING LABEL
4	9541PP	3	TILLER DANGER LABEL
5	SERIALTAG	1	SERIAL NUMBER TAG

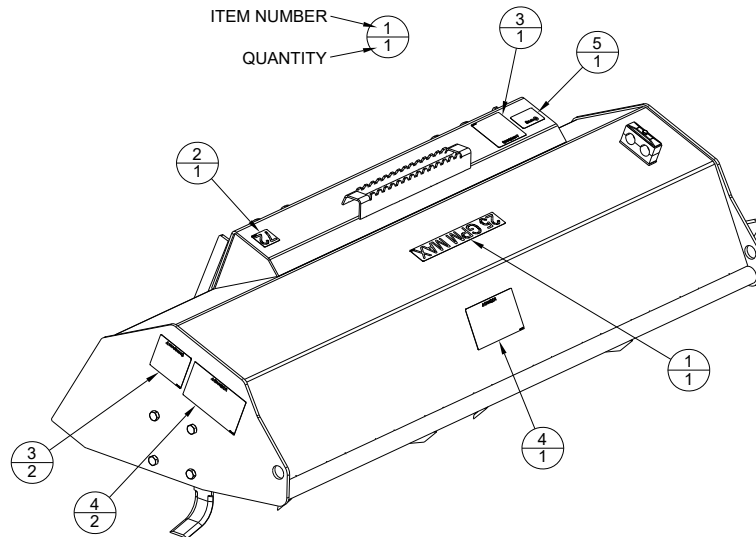

Maintenance

*Before each use and after every 10 hours of operation

- Grease bearings (2 fittings).
- Check for worn or damaged tines. Replace damaged tines as needed.
- Make sure all safety labels are in place, look in this manual for locations.
- Check for loose, worn, or missing parts, repair or replace as needed.
- Remove any foreign debris such as grass, string, wire, etc. that may have wrapped around the tiller rotor.
- Inspect motor, hydraulic fittings, and hoses for leaks and damage. Replace as needed. Make sure machine is shut off and hydraulic pressure is relieved before checking for leaks. Never use hands to check for high pressure hydraulic leaks.
- Contact your dealer for any required replacement parts.

*Before storage

- It is recommended to power wash unit before storage.
- Grease bearings (2 fittings).
- Do not store tiller sitting on the ground, place on pallet or concrete.

Tiller Tine Replacement Procedure

- Remove the 5/8" nut and bolt holding the tiller tine in the rotor tine pocket. Make note of the direction the tiller tine is oriented.
- Remove tine. With tine removed, clean dirt/debris out of tine pocket. Install new tine, orientating it the same as the one that was removed.
- Reinstall nut and bolt to retain tine.

Tiller Rotor Replacement Procedure

- Position tiller so that it is resting on the quick-tach interface plates. The use of a hoist would be useful.
- Remove the 5/8" nut and bolt that connects the Tiller Drive Adapter Weldment to the Tiller Rotor Assembly.
- Remove the four 1/2" nuts that hold the Tiller Motor Mount Weldment.
- Remove the hoses from the hose clamp (TLR72 model only).
- Remove the Hydraulic Motor with the Tiller Motor Mount Weldment from the Tiller Frame Weldment.
- Remove the 5/8" nuts and bolts that hold the Tiller Bearing Guard and Bearing on both ends of the Tiller Rotor Assembly. Since the Tiller Rotor Assembly is very heavy, it should be supported using a hoist or some equivalent lifting device.
- Remove the Tiller Rotor Assembly.
- To reinstall the Tiller Rotor Assembly, follow the above procedure in the reverse order.

Labels on Tiller Attachment



9541PP-TILLER DANGER LABEL

This label has several important instructions for safe operation regarding flying object hazards and rotational hazards.



9540PP-TILLER WARNING LABEL

All bystanders must stay clear during operation.

This label has several important instructions that must be followed for safe operation of this attachment.